

Burst Tester 1 OP

Single Head 'Open Tube' Burst Tester.



Tube Housing.
Twin skinned with accoustic foam core.

Front Door
Hinged and Interlocked.
10mm thick Clear.

Front Door Seals.
Sealed to reduce noise
transmission.

Tube Holding Mandrel.
Plastic and light weight device
which seals and secures the tube
into the cabinet during the pressurised test.

Quick Release Coupling.
Enables the tube and Mandrel assy
to be detached and removed from
the cabinet as one unit

Test Pressure Adjustment.

Air Supply In
6mm OD tube
(4-5 bar)
(not supplied with machine)

Tube being tested, fitted into
tube holding mandrel.

Door Catch.

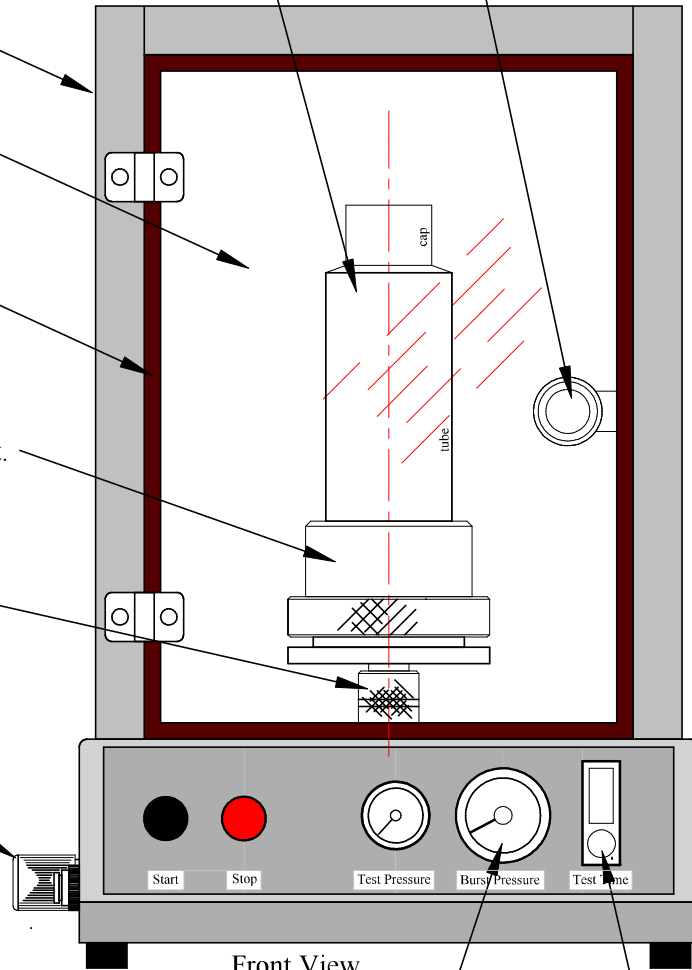

Front View.

Controls Fascia

Start	Stop	Test Pressure Gauge.	Pressure Gauge with sweep arm.	Adjustable test duration timer.
Cycle Start pushbutton	Cycle stop pushbutton	Indicates pressure required inside the tube during test.	Highest Pressure acheived during test is recorded by sweep arm.	(2 to 30 seconds)

- Max Tube Length- 280mm
- Max. Tube Dia 50 dia standard
larger sizes up to 60 dia available.
- Test Pressure Range 0-4 Bar
(specify when ordering)
- Power source-- Compressed Air Only
- Weight 18kg
- Harmonised code 842230
- Country of Origin GB

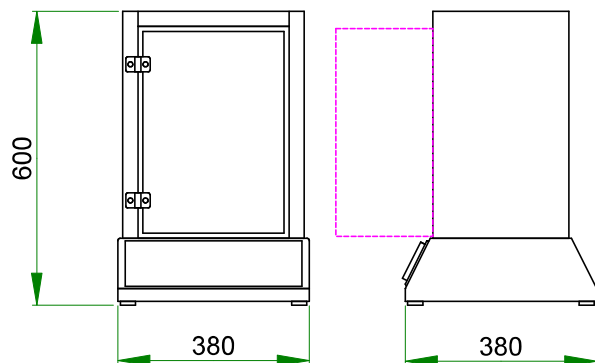

Overall dimensions.

MSD Ltd UK
Mail info@msd-ltd.co.uk
Telephone 0044 (0)1462 421400